

LIMITED WARRANTY AND LIMITATION OF LIABILITY

This pump is warranted free from material and/or manufacturing defects for three years from date of purchase (five years on select cast iron pumps). As the sole and exclusive remedy for a breach of this limited warranty, if the product is found to be defective, it will be replaced with an equivalent product if it is returned to the place of purchase with proof of purchase. Any disassembly, modification, or abuse of this product voids this limited warranty. This product is not designed for pumping flammable or corrosive fluids, and use of this product to pump such materials also voids this limited warranty.

**ALL OTHER EXPRESS OR IMPLIED WARRANTIES,
INCLUDING WARRANTIES OF MERCHANTABILITY OR FITNESS
FOR A PARTICULAR PURPOSE ARE DISCLAIMED**

IMPORTANT NOTICE: Some commercial and residential insurance policies extend coverage for damages incurred by product failure. In most cases, you will need to have possession of the product to support your claim. In the case where you need to retain possession of the product to support a damage claim you submit to your insurance company, the pump will be exchanged with an equivalent or the original price will be refunded once the claim is settled with the insurer.



OWNER'S MANUAL

INSTALLATION AND OPERATION INSTRUCTIONS FOR:

SUBMERSIBLE SUMP/EFFLUENT PUMPS

Models:

PF92305, PF92507,

PF92505, PF92509

PF91361



Carefully read and understand all of the Warnings and installation instructions in this manual. Failure to follow these instructions could lead to serious bodily injury and/or property damage. Retain these instructions for future reference.

This pump has been manufactured with your needs in mind. Properly installed in the right application, your new PROFLO Pump will give you years of carefree performance.

DANGER ⚠ Water and electricity can be dangerous if certain precautions are not adhered to. This pump is designed to operate perfectly safe in a water environment; however, improper use and installation can result in personal harm from electrical shock. Please pay attention to the following warnings.

WARNING ⚠ Never touch any electrical device, including this pump, when it is touching water, in water, or even in a moist environment. Always unplug (disconnect the electricity) when working on or installing the unit.

WARNING ⚠ **RISK OF ELECTRICAL SHOCK.** This pump is supplied with a grounding conductor and grounding-type attachment plug. To reduce the risk of electrical shock, be certain that it is connected only to a properly grounded, grounding-type receptacle.

WARNING ⚠ Do not use the power cord or discharge hose to carry or handle the pump. Doing so may cause damage to the power cord or discharge hose. Use the carrying handle supplied with the pump.

WARNING ⚠ Always use a grounded outlet. A three-prong mating type receptacle is needed for safe use. This should be in accordance with the National Electric Code and any additional codes or laws required by your local government.

NOTICE ⚠ It is strongly recommended to use a ground fault interrupt device on any electrical appliance, including this pump, when used in a wet or moist environment. This is required by many local codes and enforcement agencies.

REPLACEMENT PARTS

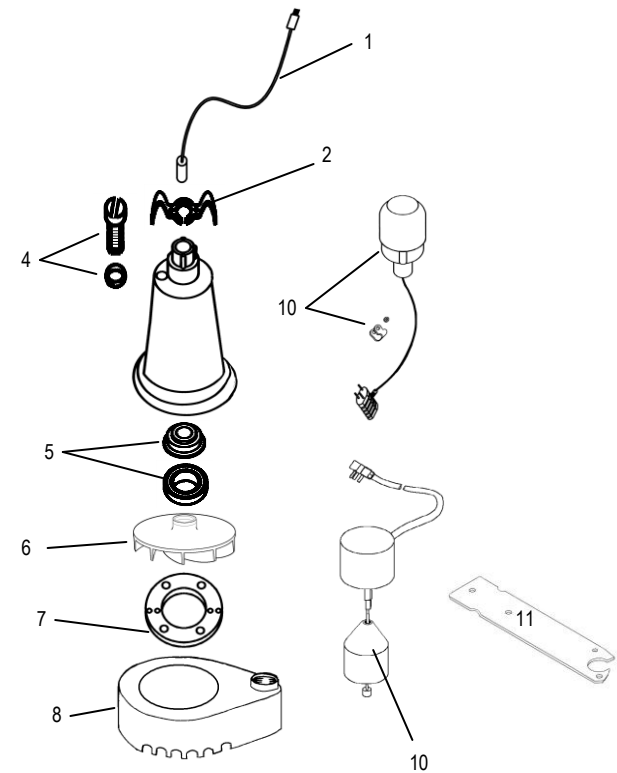

| Ref. # | Description | Parts for Models: | | | |
|--------|-------------------------------|-------------------|---------|---------|---------|
| | | PF92305 | PF92307 | PF92505 | PF92509 |
| 1 | Power Cord | N/A | N/A | N/A | N/A |
| 2 | Handle | PF99050 | PF99050 | PF99050 | PF99050 |
| 4 | Oil Fill Plug with O-ring | PF99056 | PF99056 | PF99056 | PF99056 |
| 5 | Shaft Seal | PF99057 | PF99057 | PF99057 | PF99057 |
| 6 | Impeller | PF99075 | PF99075 | PF99075 | PF99075 |
| 7 | Gasket | PF99064 | PF99064 | PF99064 | PF99064 |
| 8 | Volute/Base | PF99071 | PF99071 | PF99071 | PF99071 |
| 9 | Intake Screen for | PF99074 | PF99074 | PF99074 | PF99074 |
| 10 | Float Switch with Clamp | PF92000 | PF92010 | PF92000 | PF92010 |
| 11 | Vertical Float Switch Bracket | | PF99105 | | PF99105 |

NOTICE ⚠ Height and/or piping restriction will reduce the pump output performance. See the performance chart below to insure you have the proper pump for your application. Whenever possible use the same size or larger pipe as the pump discharge for optimum performance. Reducing the pipe size will not harm your pump; it will just reduce the output.

PERFORMANCE CHART

| Model | Output in gallons per minute at listed discharge height above pumping level | | | | | |
|------------------|---|----|-----|-----|-----|-----|
| | 0' | 5' | 10' | 15' | 20' | 25' |
| PF92305, PF92507 | 60 | 56 | 50 | 35 | 15 | 6 |
| PF92505, PF92509 | 70 | 66 | 58 | 48 | 25 | 10 |

SPECIFICATIONS

- Power supply requirements..... 120V, 60 Hz, 15 amp
- Motor..... Continuous Duty, Capacitor Start, Thermally Protected
- Amps..... 7.6
- Horsepower..... 1/3 HP (PF92305, PF92307)
1/2 HP (PF92505, PF92509)
- Liquid Temperature Range..... 32° F - 120° F (0° C - 49° C)
- Solids Handling..... 5/8"
- Discharge Size..... 1 1/2"

DANGER ⚠ Do not use this pump to pump chemicals or flammable or corrosive liquids. You could injure yourself and the pump will fail. Pumping these types of liquids voids the warranty. Make sure you purchase a pump designed for your specific needs. This pump will handle fluids with the same characteristics as water

WARNING ⚠

Your pump has thermal over-load protection built in. It is not recommended for pumping liquids over 120° F. The thermal overload protector will automatically shut down the pump in an overheat situation. It will then reset itself once the pump cools down. This overload is designed as a safety device and it will fail after repeated use. Normal operation is for fluids between 32° F & 120° F.

DO NOT RUN THE PUMP DRY. The pump depends on water for cooling and lubrication. Operating the pump without water may cause the motor to overheat or cause damage to parts of the pump. It may also shorten the life of your pump.

NOTICE ⚠

EXTENSION CORDS

For best performance, it is recommended to connect the power cord directly to the grounded GFCI outlet. If the use of an extension cord is necessary, always use a grounded waterproof type cord. Never use longer than a 25-ft. cord that is lighter than 14/3 gauge.

DANGER ⚠ Keep all electrical connections away from wet and moist environments. Wet connections can cause electrical shock resulting in personal injury.

USE AND INSTALLATION

WARNING ⚠ **ALWAYS DISCONNECT THE POWER SOURCE BEFORE ATTEMPTING TO INSTALL, SERVICE OR PERFORM MAINTENANCE ON THE PUMP. FAILURE TO DO SO MAY RESULT IN FATAL ELECTRICAL SHOCK.**

Your PROFLO Pump is designed and built to give you reliable performance and long life. It will pump water automatically for years when properly installed in the right environment.

REMOVING OLD PUMP. (If necessary)

1. Make sure power supply is disconnected.
2. After the power is off, remove the old pump. There are many different possible types of installations.
3. It is best to remove all old piping and start over with new piping. Be sure to clean all debris and dirt out of the sump basin before installing your new pump.

Be sure to have a grounded 120V AC outlet mounted within 6 ft. of your sump basin. Again, it is highly recommended that a GFCI (ground fault circuit interrupter) outlet be installed in the receptacle box.

NOTICE ⚠️ A qualified electrician must perform all wiring.

INSTALLATION (New Pump)

1. Set your new pump in the bottom of the sump basin off to one side. The pump should be placed on a solid foundation. Do not place the pump directly on the ground or sandy or rocky surfaces. Sand and small stones may clog or cause damage to your pump.
2. Make sure the float switch will operate freely from the bottom to top without coming in contact with the side of the sump basin. Contact with the side of the sump basin may cause the switch to malfunction. See figure below.

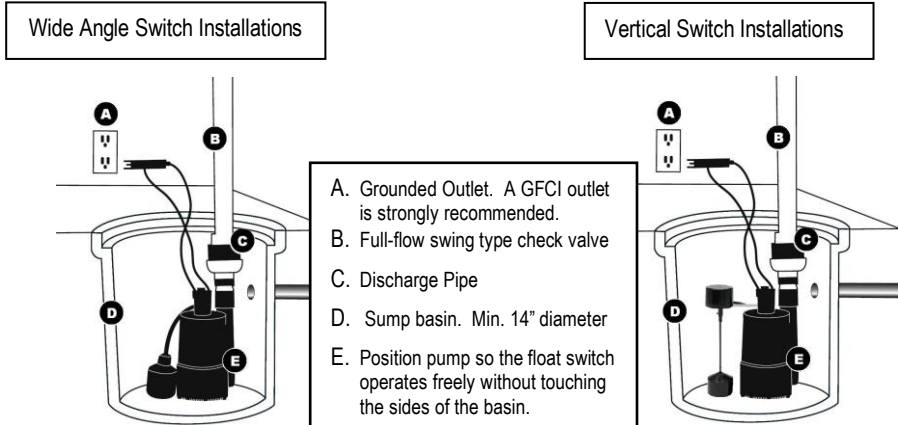

3. It is highly recommended to install a full flow, swing type check valve (not included) as close to the discharge outlet on the pump as possible. A new check valve will greatly increase the life of your pump. The check valve should be the same size as the pump discharge.
4. Connect the pump and check valve together using schedule 40 PVC pipe and fittings. You can also use DWV or ABS pipe, as this is not a pressure installation. Corrugated drain hose is intended for temporary use and should not be used in a permanent installation.
5. Test your installation after you have completed setting up the pump. Plug the cord from the pump into the piggyback plug of the float switch, then plug that into your grounded outlet. The pump should not run at this point. If the pump runs, the switch is stuck in the upright position or the pump is plugged directly into the outlet and not through the piggyback switch plug. Fill the sump basin with water using buckets or a hose. When the switch floats to the upright position, the pump will turn on. The switch will turn off the pump when it reaches the down position. You may adjust the switch to meet your particular needs. Remember the switch must operate freely without touching the sides of the sump basin. NOTE: The cut out (turn off) setting is the only adjustment available on vertical type switches

| TROUBLESHOOTING | | |
|---|--|--|
| PROBLEM | POSSIBLE CAUSES | HOW TO CORRECT |
| If the pump does not start or run | ▪ Pump is not plugged in, switch or breaker is off | ▪ Plug pump in or turn on switch/breaker |
| | ▪ Check for blown fuses or tripped circuit breakers or tripped GFCI outlets | ▪ Replace fuse, reset breaker, reset GFCI outlet |
| | ▪ Float switch is defective | ▪ Check and replace if necessary |
| | ▪ Motor thermal protector tripped | ▪ Allow pump to cool. Pump will reset |
| | ▪ Float switch is stuck or obstructed | ▪ Remove obstruction or position pump so it will not become stuck |
| The pump starts and stops too often | ▪ Backflow of water from discharge hose/pipe | ▪ Install or replace check valve |
| | ▪ Float switch is defective | ▪ Replace float switch |
| If the pump runs but moves little or no water | ▪ Clogged intake screen | ▪ Clean or replace screen |
| | ▪ Clogged discharge hose/pipe | ▪ Remove clog |
| | ▪ Frozen discharge hose/pipe | ▪ Allow hose/pipe to thaw |
| | ▪ Pump is air locked | ▪ Clean out airlock hole with a paper clip or pipe cleaner |
| | ▪ Low line voltage | ▪ Check wire size and increase if necessary |
| | ▪ Check valve is stuck in the closed position | ▪ Inspect, repair or replace if necessary |
| | ▪ Check valve is installed backwards | ▪ Make sure valve is installed in the correct direction of flow |
| | ▪ Worn, damaged or clogged pump parts | ▪ Inspect for wear, damage or clog and clean or replace if necessary |
| ▪ Discharge head exceeds pump capacity | ▪ If pumping height is over 25', the pump will not move water. See performance chart | |
| Pump does not shut off | ▪ Float switch is obstructed or stuck | ▪ Remove obstruction |
| | ▪ Defective Float Switch | ▪ Replace switch |